

Задание для группы 3  
(17 Сибирская заочная олимпиада по оригами 2014)

*Снежинка*

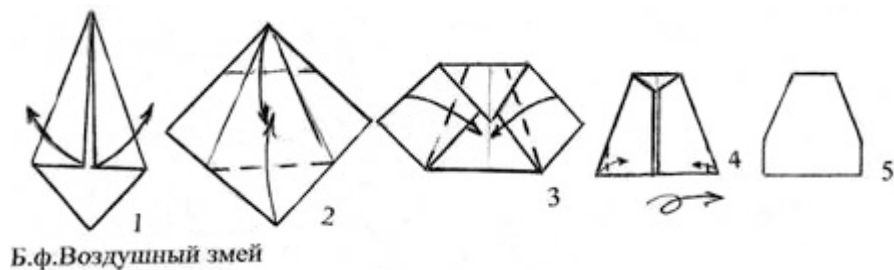

Узор для снежинки придумать!

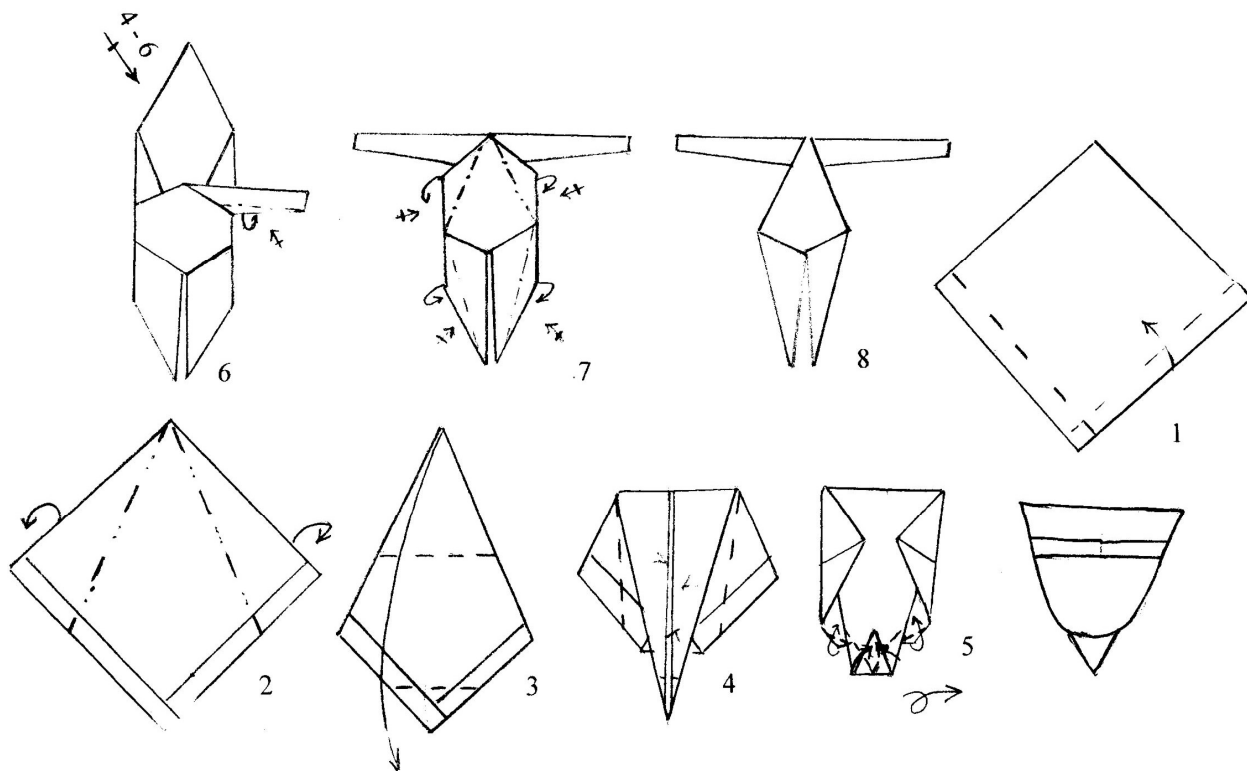
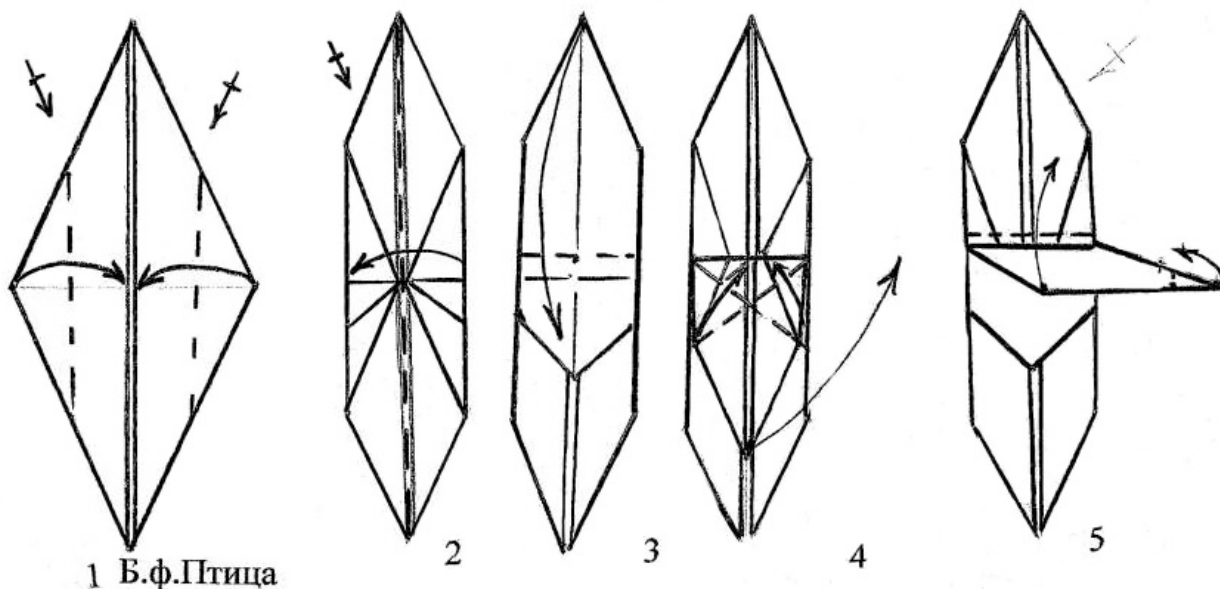
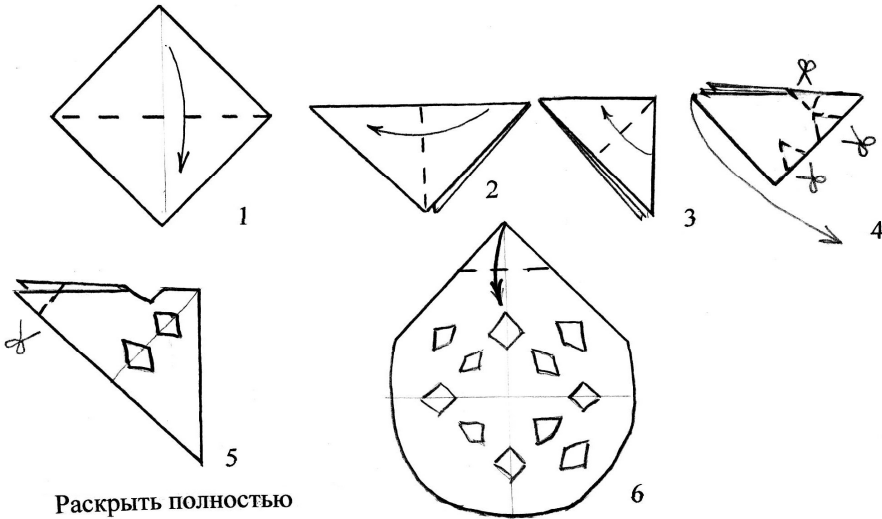

Раскрыть полностью

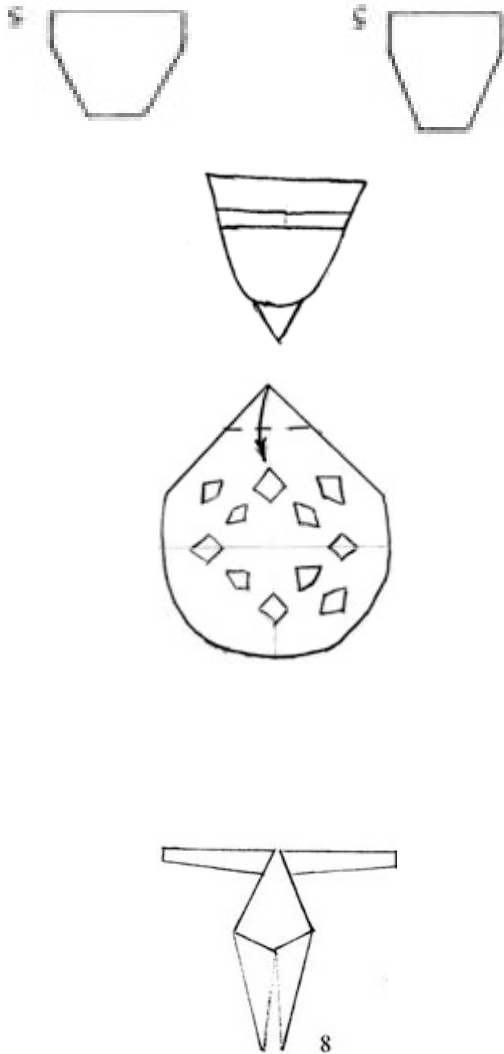
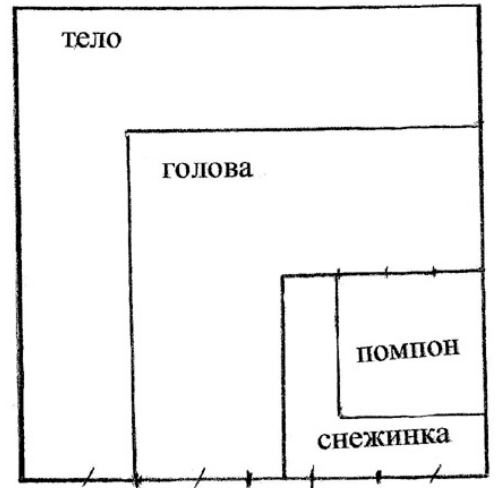

# Лучик

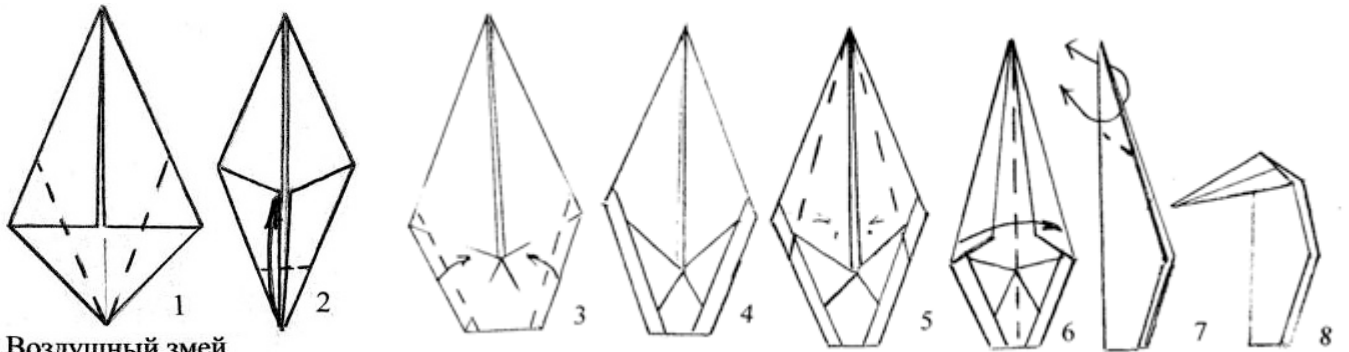
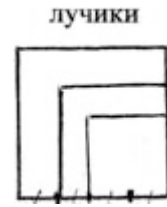

Б.ф. Воздушный змей

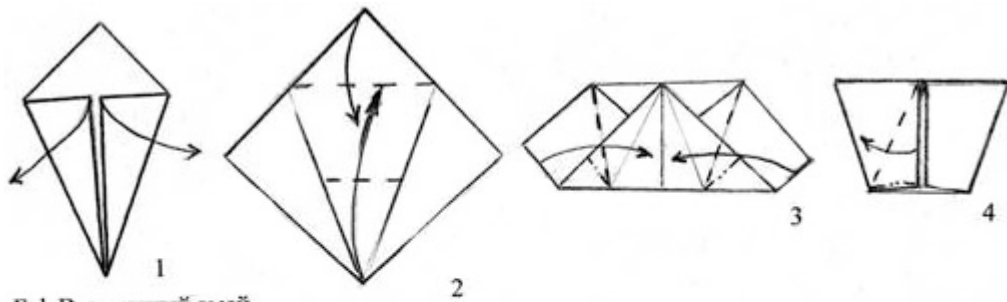
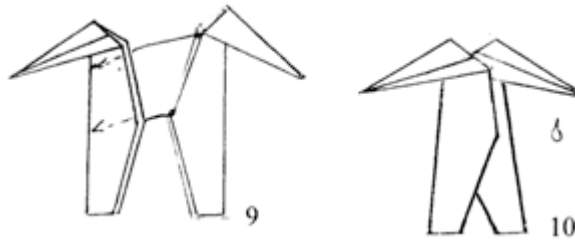

Б.ф. Воздушный змей



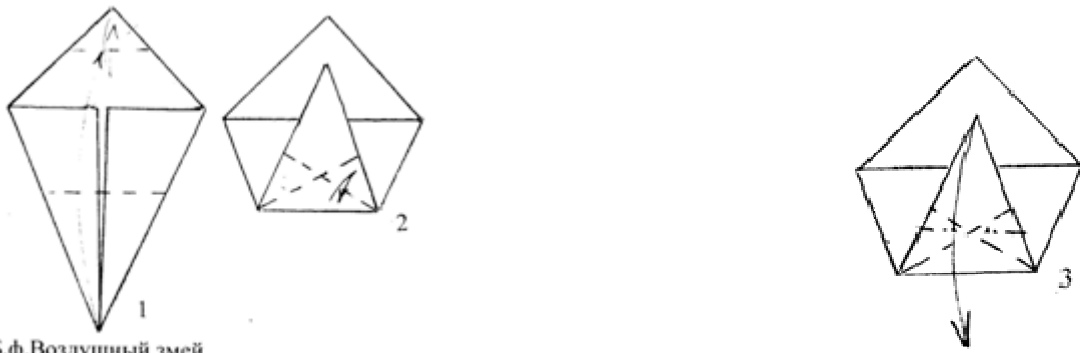

Б.ф.Воздушный змей

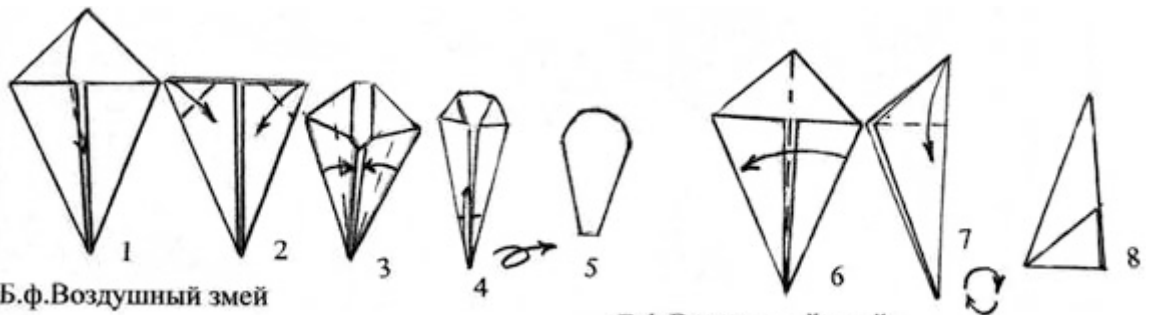
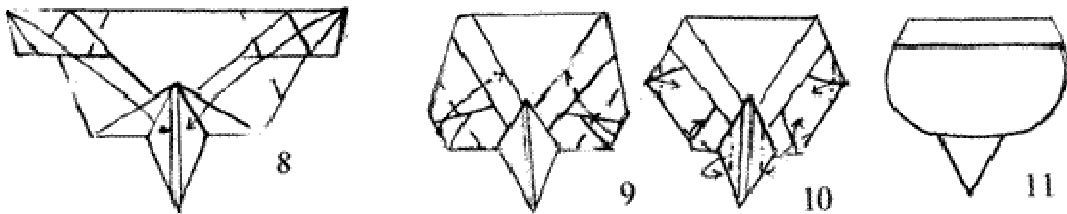
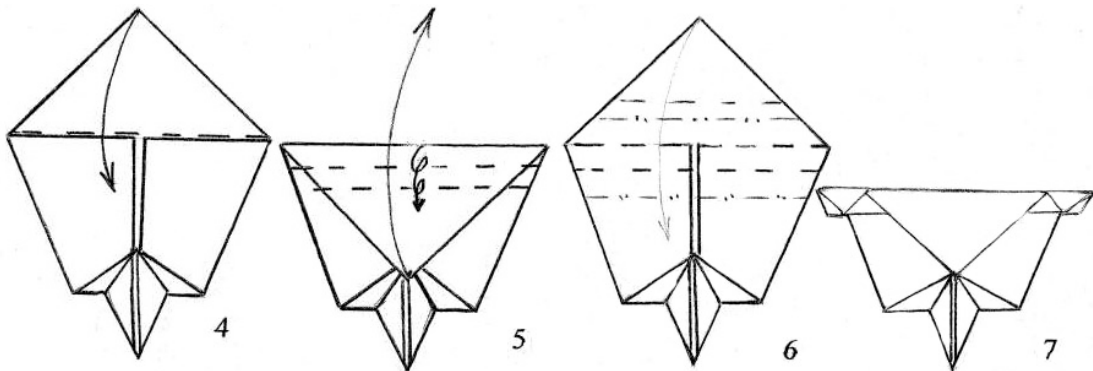

Б.ф.Воздушный змей

Б.ф.Воздушный змей

